



INSTALLATION, OPERATION *and* USER'S MANUAL

SUBURBAN STOW AWAY STAIRS

MODELS:

SOP-1101B, SOP-1102B
SOP-1103B, SOP-1104B
SOP-1105B, SOP-1106B

 **Suburban**

A Division of AIRXCEL

▲ DANGER

During deployment, do not drop product onto the ground. Injury may result if the product is not controlled by user during deployment.

Injury may result if the surrounding area is not clear of obstacles, people, animals and trip hazards during deployment.

Always keep fingers away from threshold cover and hinge plate assembly during deployment.

This product is rated for a maximum weight carrying capacity of 500lbs when installed according to this manual. Exceeding this capacity can cause personal injury or loss of life.

▲ WARNING

Improper installation, adjustment, alteration, service or maintenance can cause property damage, personal injury or loss of life. Refer to the installation instructions and/or owners manual provided with your product. The permanent removal and reinstallation of the product as well as the installation of component parts must be made by a qualified installer or service center.

Installation of this product must be made in accordance with the written instructions provided in the manual. No agency, representative or employee of Airxcel, Inc., Suburban Division or other person has the authority to change, modify or waive any provision of the instructions contained in the manual or instruction sheet.

▲ WARNING

Always extend the legs to fully contact the ground before climbing or descending stairs.

Always wear appropriate personal protective equipment when installing or servicing this product. This may include the use of safety glasses, gloves and closed-toed shoes.

Floor of RV must have equivalent screw withdrawal resistance of 1/2" or thicker plywood in order to ensure strong connection between floor and staircase. Failure to comply could result in unexpected detachment of product and injury to user.

▲ CAUTION

Do not use this product if any component shows evidence of damage.

TABLE OF CONTENTS



PRODUCT SELECTION	2
INSTALLATION INSTRUCTIONS	2
OPERATING INSTRUCTIONS	3
CLEANING AND MAINTENANCE	3
TEMPORARY REMOVAL OF PRODUCT	3
SPECIFICATIONS	4
REPLACEMENT PARTS	5
ONE YEAR LIMITED WARRANTY	8

PRODUCT SELECTION



The Suburban stairs are available in 2-step/3-step/4-step, narrow/wide configurations. To select the appropriate stair model for your RV, two dimensions are needed from the RV:

1. Door Opening (See **Figure 5**, Dim A)
Measure the inside dimension of your door flanges and select a narrow or wide configuration.
2. Ground to RV floor height (See Specifications, Dim B)
With RV on level ground, measure the vertical distance between the ground and RV floor.
Note - Ensure you measure to the floor, not the top of your door's threshold.

Consult the Specifications section to select the appropriate model.

INSTALLATION INSTRUCTIONS



Pre-installation Notes

Ensure the RV has been properly leveled before installation.

Though it is possible to install this product with one person, a second person is recommended.

If applicable, remove threshold transition strip from behind the threshold.

The stair assembly may be quickly removed from the RV completely, if desired, without the use of tools.

Tools Needed:

- Tape Measure
- Electric Drill Driver
- #2 Square Drive Bit (preferred) or #2 Phillips Drive Bit
- 1/8" Drill Bit
- 5/32" Allen Wrench

Installation

Read this entire procedure before installation.

1. This product is installed in the retracted/up position in order to secure the floor mounting bracket screws.
2. Open RV entry door fully and set the stair assembly in the RV threshold as shown in **Figure 1**.
3. Use the threshold cover to square the assembly to the RV entryway by pushing the stair assembly fully against the outside vertical face of the threshold.
4. Center the stairs side-to-side within the left and right door flanges.
 - Adjustments to the latch brackets have been made by the factory to install directly into a 26" or 30" door depending on model ordered. For these two door widths, slight adjustments may be needed to perfect the latch engagement onto the door flange.
 - For other door widths within the product's allowable adjustment range, measure the door flange inside width and pre-adjust the latch brackets to aid installation. (See Latch Bracket Adjustment procedure below). This will allow the brackets to rest onto your door flange, stabilizing the product throughout the remainder of installation.
5. The following steps involve installation of floor mounting screws to secure product to floor. Eight (8) #10x3/4 pan head or truss head screws must be used. Ensure screw head diameter of 5/16" or larger is used. Washers may also be used.
6. Install one (1) screw through floor mounting brackets slotted holes, centered as shown in **Figure 2**, (screw position A). Installation of screws into slotted holes first allows for fine adjustment of staircase within the door width. It is recommended to drill a pilot hole using a 1/8" drill bit for all floor screws.
7. Ensure stairs are centered within doorway before installing remaining screws in the floor mounting bracket. Once satisfied with position, install remaining screws in the floor mounting bracket as shown in **Figure 2**, (screw position B). Do not overtighten screws.
8. Close entry door(s) and ensure adequate clearance exists between stairs and door(s). Repeat this step after deployment of the staircase.

Latch Bracket Adjustment

Latch brackets may need adjustments to engage the door flange properly. At least ½” of the bracket face width should contact the door flange to ensure sufficient contact.

CAUTION

Insufficient bearing of brackets onto door flange may result in damage to the door flange or RV.

Adjust brackets by loosening bolts shown in **Figure 1**, sliding brackets in or out as needed and retightening bolts. The ideal adjustment is achieved when maximum surface area of each stop bracket bears on the door flanges and the slide latch actuates properly to prevent the staircase from unintentionally pulling free from the door flange.

OPERATING INSTRUCTIONS



To deploy the staircase, fully open entry way door to access stairs. With a firm grip on a stair tread, release the latch from door flange by pulling on red handle and pivot the product out of the doorway. The legs must then be extended to contact the ground before using the staircase.

Two methods for deploying the legs:

1. With one hand, lift staircase until treads are level. With the other hand, depress leg latch on back side of leg housing to allow legs to extend and contact the ground as shown in **Figure 3**. Fine adjustments may be needed to accommodate uneven terrain.
2. Depress the leg latch on back side of leg housing to allow legs to extend and contact the ground. Hold the leg foot firmly in contact with the ground using your foot and simultaneously lift a stair tread until level. Repeat this process to deploy the other leg.

CLEANING AND MAINTENANCE



- All components and surfaces of the staircase may be washed with soap and water. Care should be taken not to use solvents on labels or tread grip tape as these components may be inadvertently detached.
- The leg's latch and rack components should be inspected with each use to ensure components are clean and free of debris or defects. This will ensure a long life and smooth leg operation.
- The legs are retained within their leg housings to ensure they are not inadvertently removed completely during deployment. The retainment spring button may be depressed to fully remove the leg if deep cleaning is desired. To disengage the retainment mechanism refer to **Figure 3**.
- The threshold cover is fixed to the floor in the downward position. If cleaning under this plate is desired, the stairs must first be removed.

TEMPORARY REMOVAL OF PRODUCT

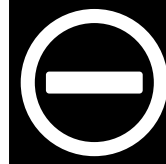

1. To remove, open entry door(s) and pull both hinge pins inward from hinge plates as shown in **Figure 4**.
2. Remove product.
3. Reinstallation is the reverse of the steps above. Ensure hinge pins are fully reinstalled before using the product.

SPECIFICATIONS

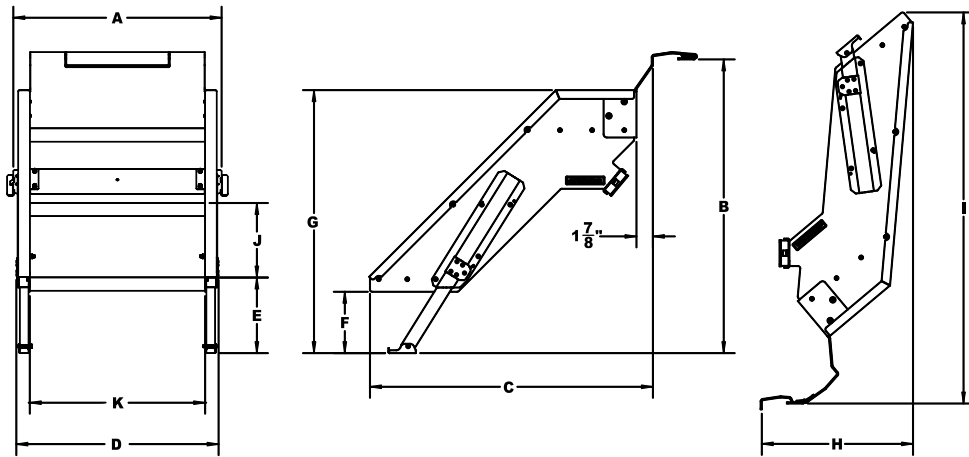

DIM	DESCRIPTION	2-STEP		3-STEP		4-STEP	
		NARROW	WIDE	NARROW	WIDE	NARROW	WIDE
	Nominal Door Width	26" - 30"	30" - 34"	26" - 30"	30" - 34"	26" - 30"	30" - 34"
A	Door Opening, Latch Adjustment	23 ¹ / ₄ " - 28 ³ / ₄ "	26 ³ / ₄ " - 32 ¹ / ₄ "	23 ¹ / ₄ " - 28 ³ / ₄ "	26 ³ / ₄ " - 32 ¹ / ₄ "	23 ¹ / ₄ " - 28 ³ / ₄ "	26 ³ / ₄ " - 32 ¹ / ₄ "
B	Floor Height from Ground	19 ¹ / ₁₆ " - 28 ⁷ / ₁₆ "		27 ⁹ / ₁₆ " - 37 ³ / ₁₆ "		36 ¹ / ₁₆ " - 45 ¹¹ / ₁₆ "	
C	Extension from Coach	24 ⁵ / ₈ "		32 ⁵ / ₈ "		41 ¹ / ₈ "	
D	Width Excluding Latch	23 ¹ / ₁₆ "	26 ⁹ / ₁₆ "	23 ¹ / ₁₆ "	26 ⁹ / ₁₆ "	23 ¹ / ₁₆ "	26 ⁹ / ₁₆ "
E	First Step Height	2 ¹ / ₁₆ " - 12 ¹ / ₁₆ "		2 ¹ / ₁₆ " - 12 ⁵ / ₁₆ "		2 ¹ / ₁₆ " - 12 ⁵ / ₁₆ "	
F	Bottom of Stringer to Ground	1 ¹ / ₁₆ " - 10 ⁷ / ₁₆ "		1 ¹ / ₁₆ " - 10 ¹¹ / ₁₆ "		1 ¹ / ₁₆ " - 10 ¹¹ / ₁₆ "	
G	Top of Stringer to Ground	15 ⁹ / ₁₆ " - 24 ¹⁵ / ₁₆ "		24 ¹ / ₁₆ " - 33 ¹¹ / ₁₆ "		32 ⁹ / ₁₆ " - 42 ³ / ₁₆ "	
H	Inside Depth from Threshold	16 ³ / ₁₆ "		17 ¹ / ₄ "		18 ⁵ / ₁₆ "	
I	Inside Height Above Floor	32 ⁵ / ₈ "		44 ⁵ / ₈ "		56 ⁹ / ₁₆ "	
J	Step Height/Rise	8 ¹ / ₂ "					
K	Step Width	20"	23 ¹ / ₂ "	20"	23 ¹ / ₂ "	20"	23 ¹ / ₂ "
	Top Step Depth/Run	13"					
	Common Step Depth/Run	8 ¹ / ₂ "					
	Tread & Leg Material	6061 Aluminum					
	Hinge, Latch & Stringer Material	Steel					
	Color	Flat Black Powder Coat					
	Load Limit	500 lbs					
	Total Product Weight	37lbs	42lbs	45lbs	50lbs	53lbs	58lbs
	Regulatory Compliance	Conforms to RVIA RVEC-1					

REPLACEMENT PARTS



KEY	PART NO.	DESCRIPTION	KIT QTY
1	521365	Leg w/ Foot Left	1
2	521362	Leg w/ Foot Right	1
3	521363	Latch Bracket w/ Latch and Handle	1
4	521364	Latch Bracket Only	1
5	525062	Grip Tape Kit	9
6	525172	Hinge Pin Kit	2
7	525173	Floor Mounting Screw Kit	7

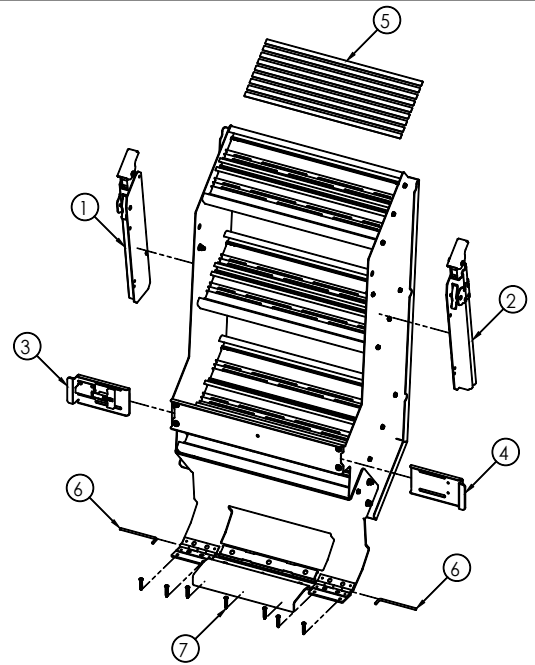

Figure 1

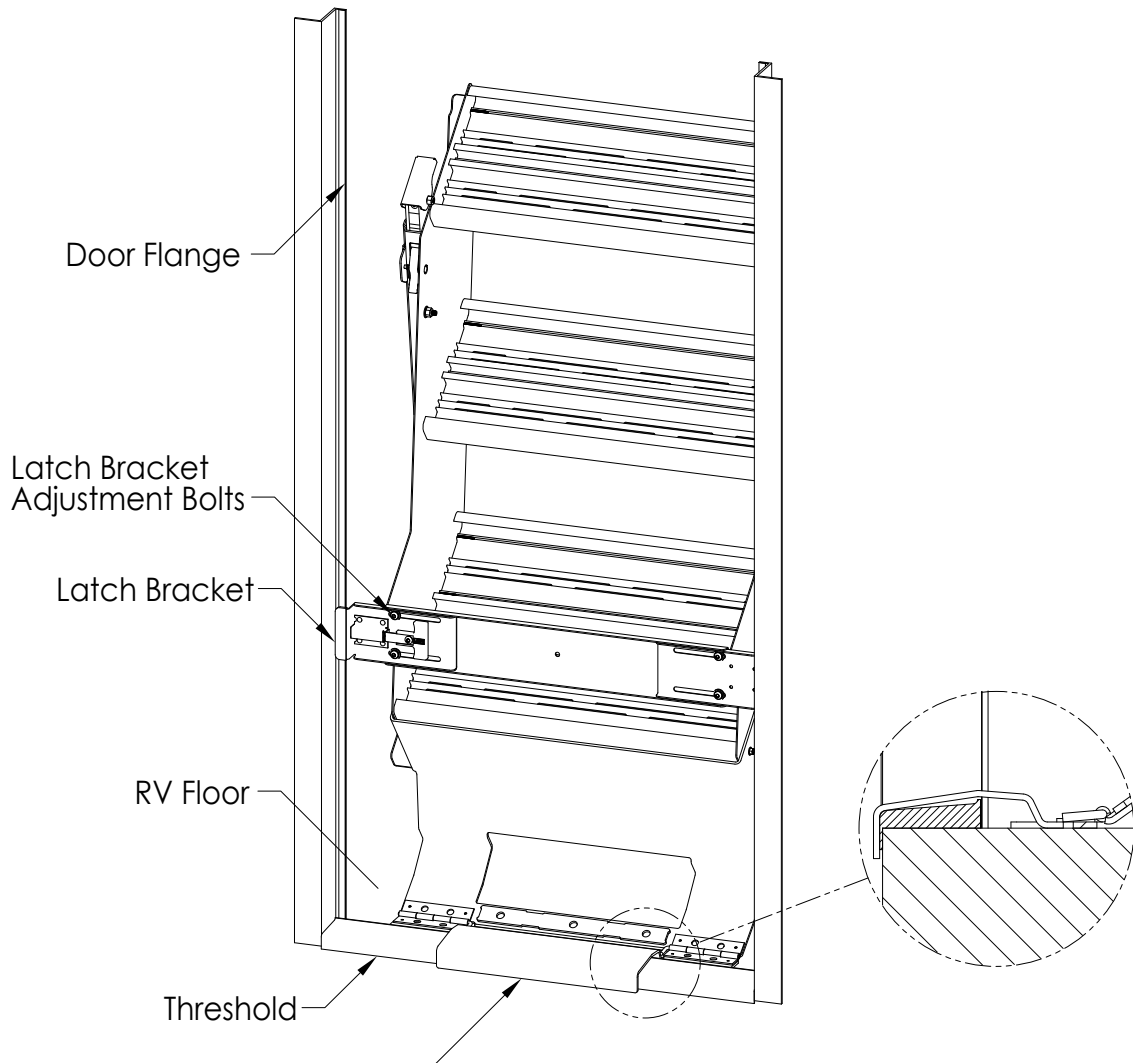

Figure 2

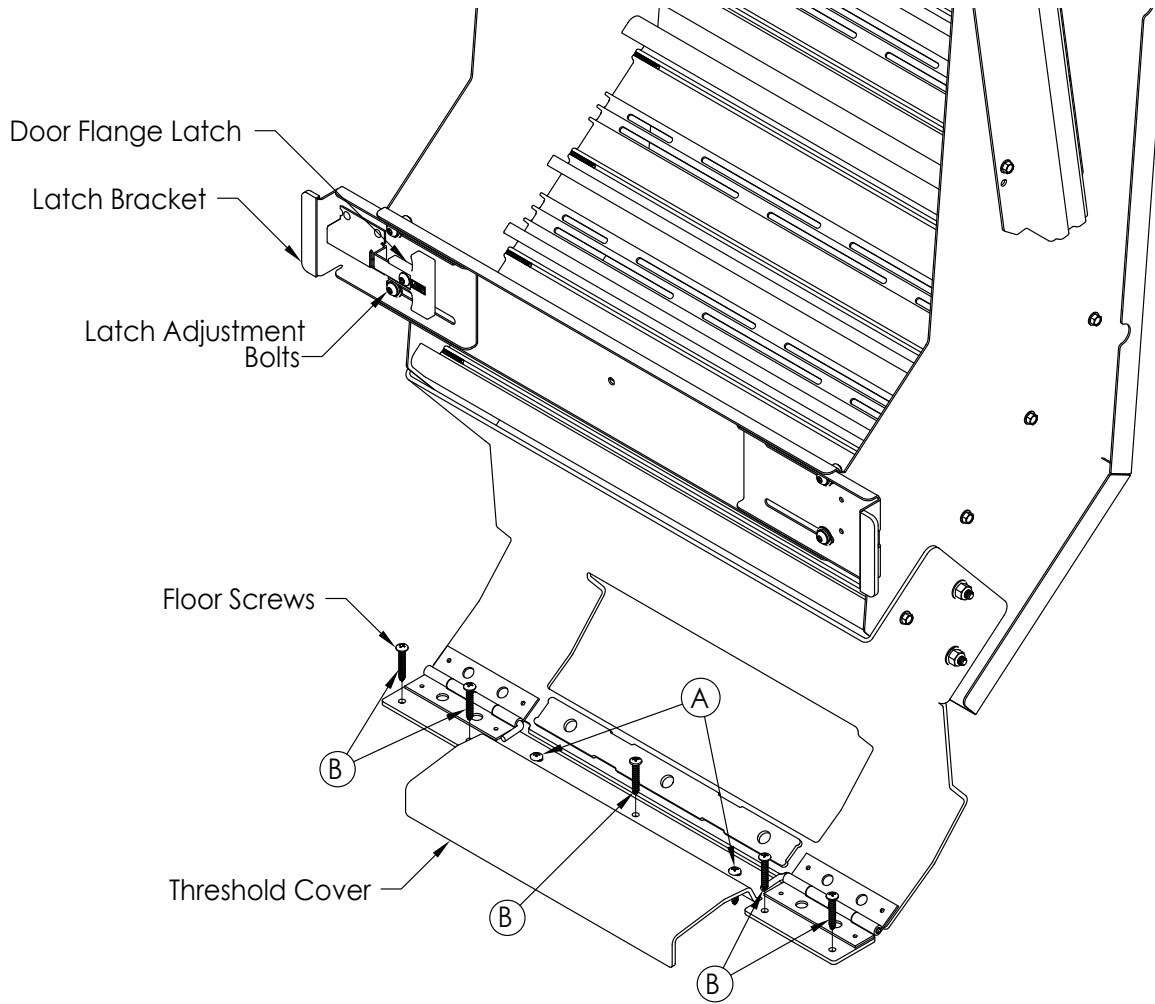

Figure 3

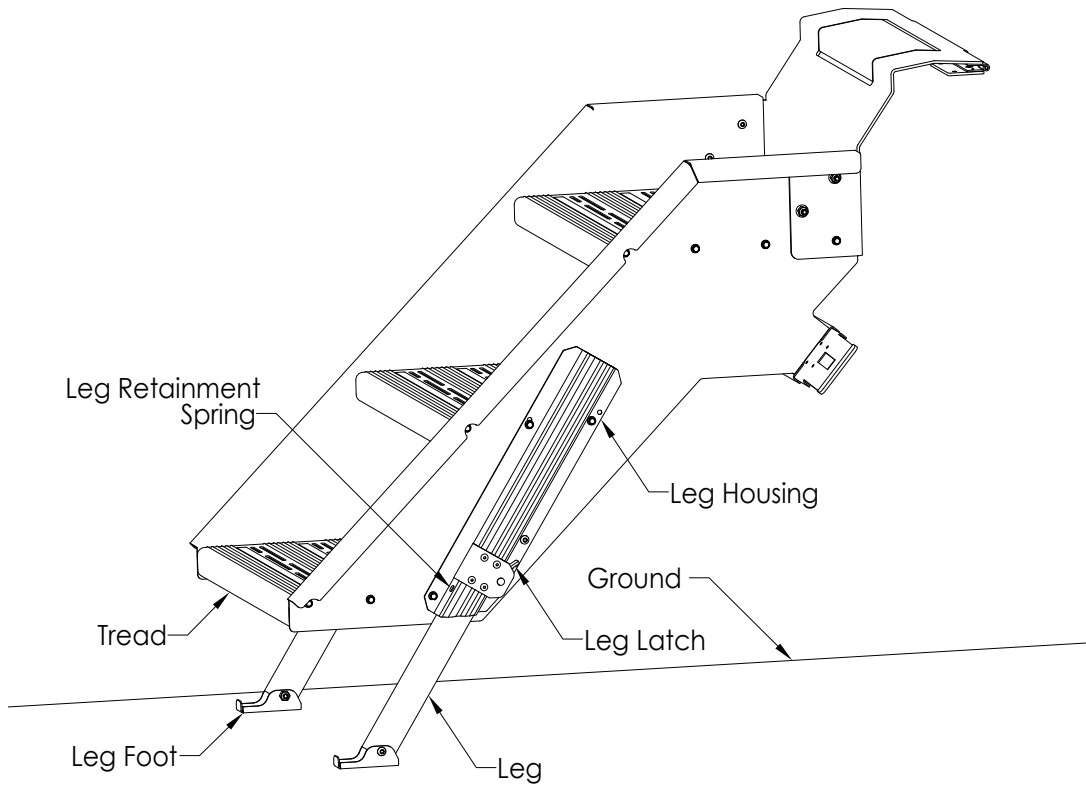

Figure 4

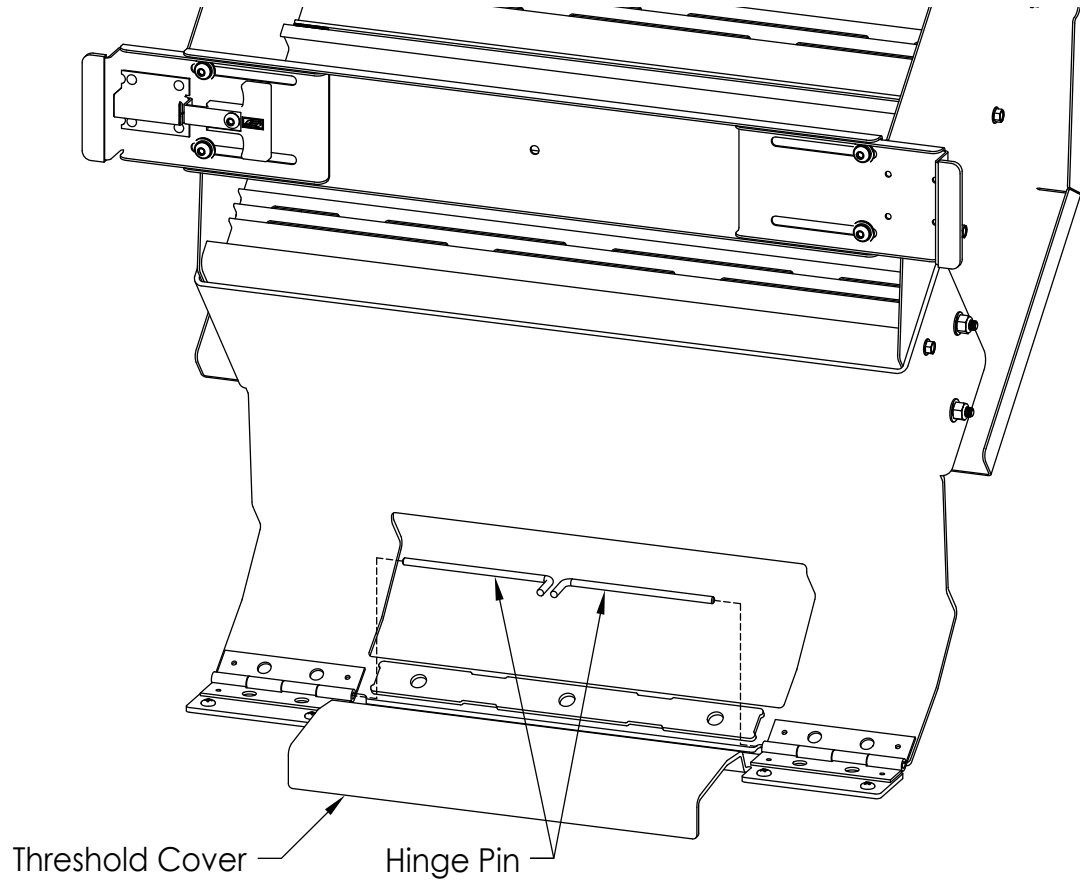
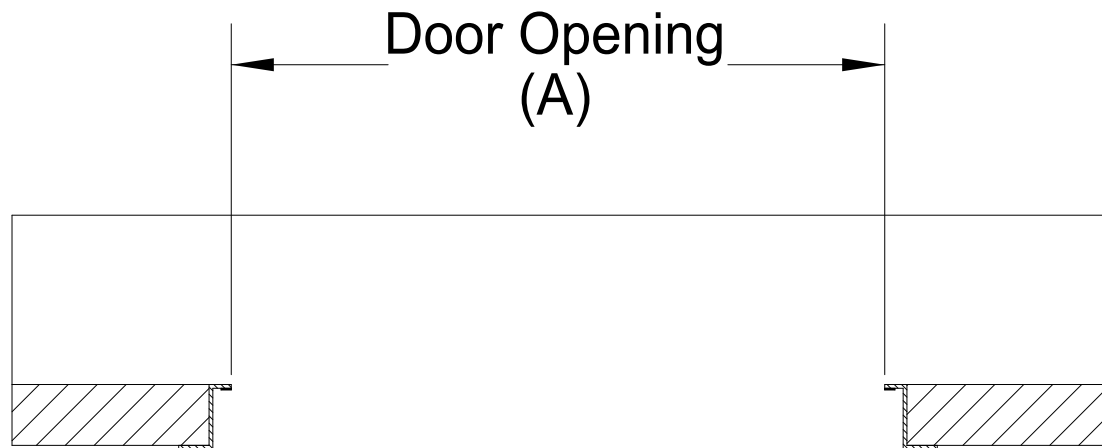

Figure 5



Top-Down Section View

ONE YEAR LIMITED WARRANTY

Please read and retain this warranty. Suburban does not require Warranty Registration for this appliance.



This product is warranted to the original purchaser to be free from defects in material or workmanship for a period of ONE YEAR from the date of the original retail purchase. It is the responsibility of the consumer/owner to establish the warranty period by supplying PROOF OF PURCHASE. Suburban, An Airxcel Brand; hereafter referred to as Suburban, does not use warranty registration. Therefore, you are required to furnish proof of purchase date through a receipt or other payment records when submitting a warranty service claim.

This warranty does not cover defects or damage due to improper installation, alteration, accident or any other event beyond the control of Suburban. Defects or damage resulting from misuse, abuse or negligence will void this warranty. This warranty does not cover scratching or damage that may result from normal usage.

Suburban will replace any parts that are found defective within the first year and will pay a warranty service allowance directly to the recommended Suburban service center at rates mutually agreed upon between Suburban and its recommended service centers. Replacement part will be shipped FOB the shipping point within the Continental United States, Alaska, and Canada to the recommended service center performing such repairs. All freight, shipping, and delivery costs shall be the responsibility of the owner. The exchanged part or unit will be warranted for only the expired portion of the original warranty. Before having warranty repairs made, confirm that the service agency is a recommended service center for Suburban. **DO NOT PAY THE SERVICE AGENCY FOR WARRANTY REPAIRS; SUCH PAYMENTS WILL NOT BE REIMBURSED.** Suburban reserves the right to examine the alleged defect in the product or component parts, and it is the owner's obligation to return the product and/or component parts to Suburban or its representative. When returning a product, it must include all component parts and the model number and date code plate. Returned component parts must be individually tagged and identified with the product's model number, date code, and date of installation.

This warranty is nontransferable and is expressly limited to the repair or replacement of the defective product.

Suburban's liability hereunder is limited to the replacement of the product, repair of the product or replacement of the product with a reconditioned unit at the discretion of Suburban. Suburban reserves the right to make substitutions to warranty claims if parts are unavailable or obsolete.

Suburban shall not be liable for loss of use of the product or other consequential or incidental costs, expenses or damages incurred by the consumer of any other use. The user assumes all risk of injury resulting from the use of this product.

This warranty is expressly in lieu of all other warranties, expressed or implied, including warranties of merchantability or fitness for use to the extent permitted by Federal or state law. Neither Suburban nor any of its representatives assumes any other liability in connection with this product.

Some states do not allow the exclusion of incidental or consequential damages, so the above limitation may not apply to you.

NO REPRESENTATIVE, DEALER, RECOMMENDED SERVICE CENTERS OR OTHER PERSON IS AUTHORIZED TO ASSUME FOR SUBURBAN ANY ADDITIONAL, DIFFERENT OR OTHER LIABILITY IN CONNECTION WITH THE SALE OF THIS Suburban, An Airxcel Brand PRODUCT.

This warranty gives you specific legal rights, and you may also have other rights which vary from state to state.

SUBURBAN WILL NOT BE RESPONSIBLE FOR:

- Any damage (cracks, chips, scratches, etc.) to any painted surface, discoloration or surface rusting.
- Items classified as normal maintenance.
- Damage or repairs required as a consequence of faulty or incorrect assembly or application not in conformance with Suburban instructions.
- Failure to operate due to dirt or debris in mechanisms.
- Parts not supplied by Suburban.
- Damage or repairs needed as a consequence of any misapplication, abuse, unreasonable use, unauthorized alteration, improper service, improper operation or failure to provide reasonable and necessary maintenance.
- Suburban products whose model number and date code plate has been altered, defaced or removed.
- Suburban products installed or warranty claims originating outside the Continental U.S.A., Alaska, Hawaii and Canada.
- Damage as a result of floods, winds, lightning, accidents, corrosive atmosphere or other conditions beyond the control of Suburban, An Airxcel Brand.
- ANY SPECIAL, INDIRECT OR CONSEQUENTIAL PROPERTY, ECONOMIC OR COMMERCIAL DAMAGE OF ANY NATURE WHATSOEVER.

IF YOU HAVE A PRODUCT PROBLEM,

If warranty service is required, return product to your dealer and/or retailer for refund or replacement; or contact Suburban, An Airxcel Brand Customer Service Department at 423.775.2131 EXT 7101.

Be sure to have the model and date code, proof of purchase and the nature of the problem readily available.

FOR FUTURE REFERENCE, YOU SHOULD RECORD THE FOLLOWING INFORMATION:

MODEL NUMBER:	
STOCK NUMBER:	
DATE OF PURCHASE:	



An Airxcel Brand

676 Broadway Street | Dayton, TN 37321 | USA
423.775.2131 | www.Airxcel.com